

Table with columns: Nome, Seção (cm), X (cm), Y (cm), Carga Máx (kN), Carga Mín (kN), Pilar (Mx Máximo (kN.m), My Máximo (kN.m), Fx Máximo (kN), Fy Máximo (kN)), Fundação (Nome, Lado B (cm), Lado H (cm), h0 / ha (m), h1 / hb (m), df (m)).

Table with columns: Localização no eixo X (Coordenadas (cm), Nome), Localização no eixo Y (Coordenadas (cm), Nome).

Table with columns: Nome, Seção (cm), X (cm), Y (cm), Carga Máx (kN), Carga Mín (kN), Pilar (Mx Máximo (kN.m), My Máximo (kN.m), Fx Máximo (kN), Fy Máximo (kN)), Fundação (Nome, Lado B (cm), Lado H (cm), h0 / ha (m), h1 / hb (m), df (m)).

Table with columns: Localização no eixo X (Coordenadas (cm), Nome), Localização no eixo Y (Coordenadas (cm), Nome).

Os esforços indicados nesta tabela são os valores máximos obtidos pela envoltória de todas as combinações definidas para as fundações. Para análises complementares, deve-se consultar o relatório de esforços na fundação, que apresenta os valores calculados para cada combinação.

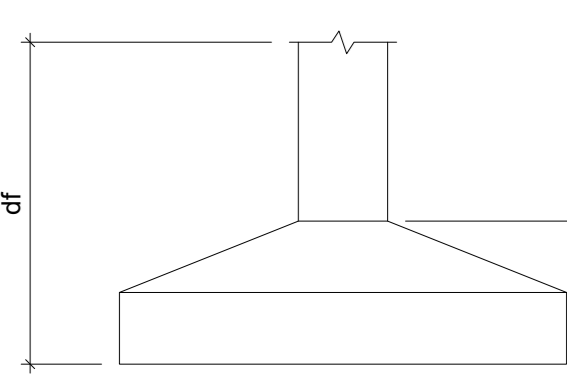
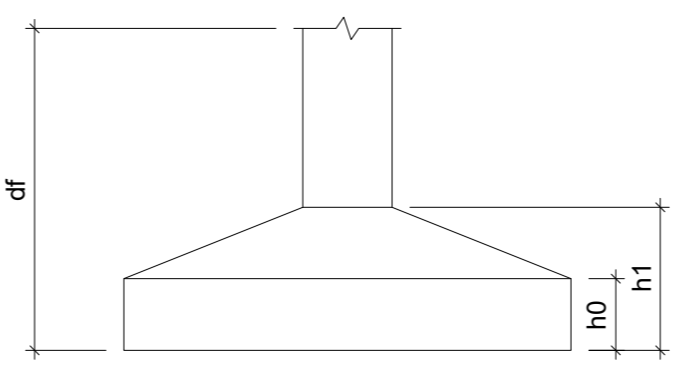

S1=S15=S44=S45=S46=S47=S48=S49=S50=S51=S52=S53

P1=P45=P47=P50=P52

P15

P44=P46=P48=P49=P51

P53

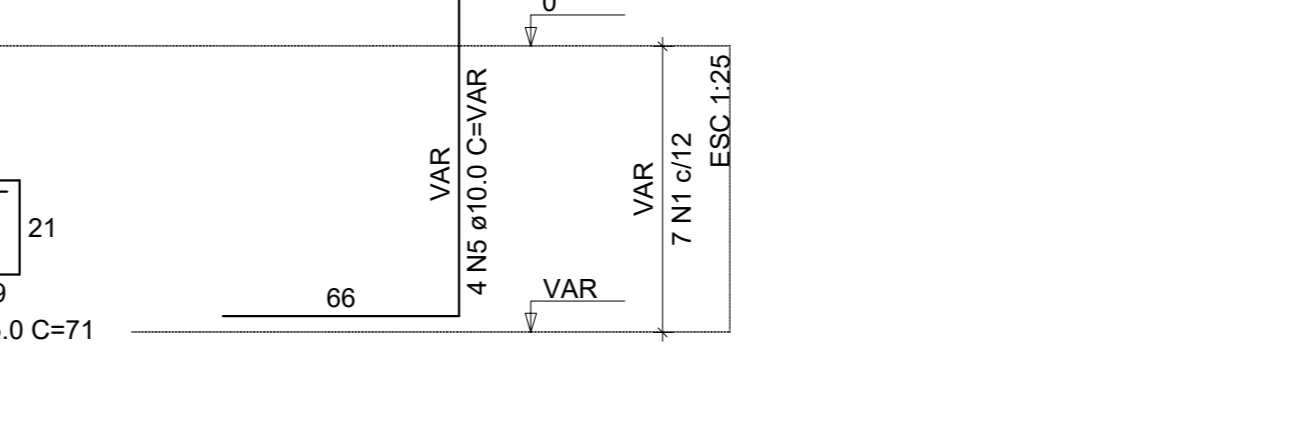
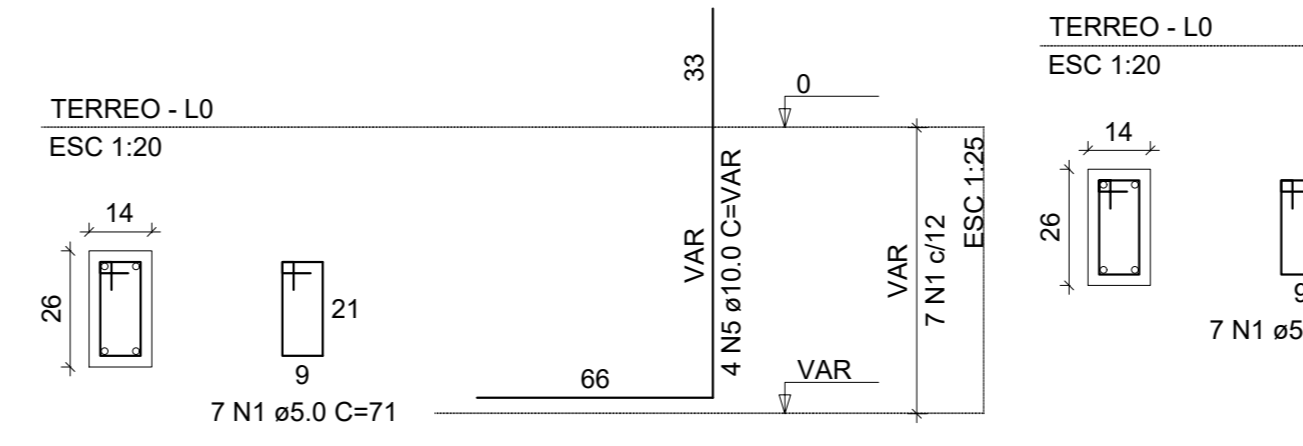
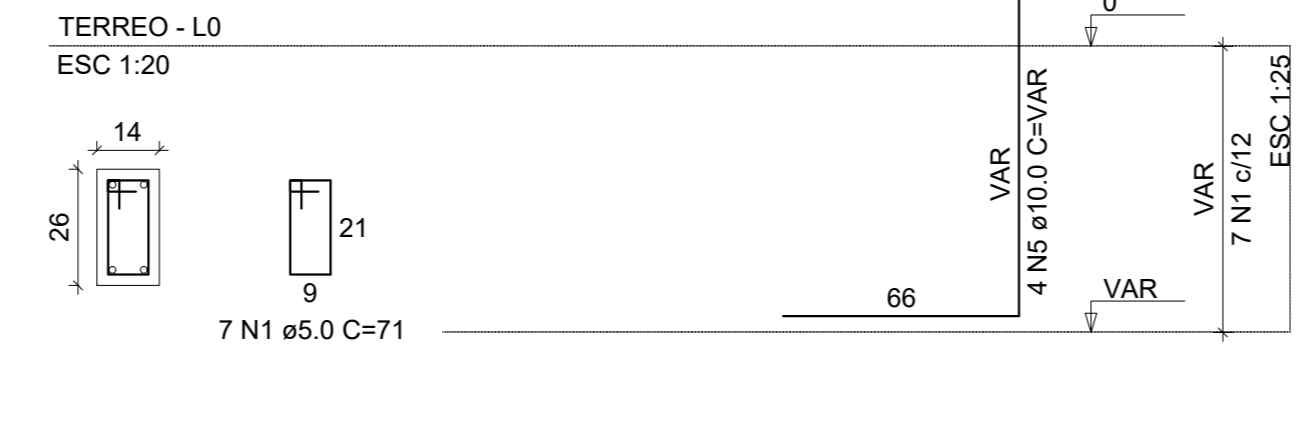
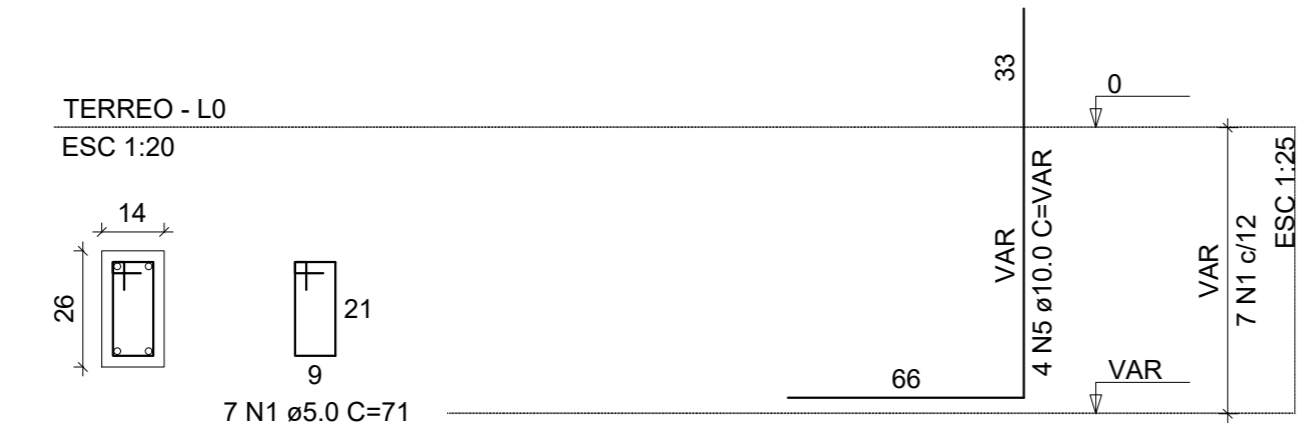
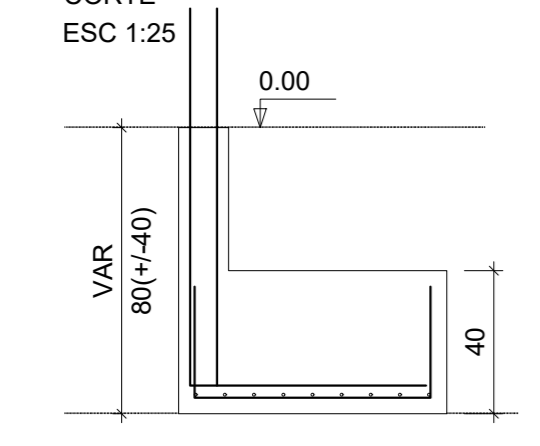
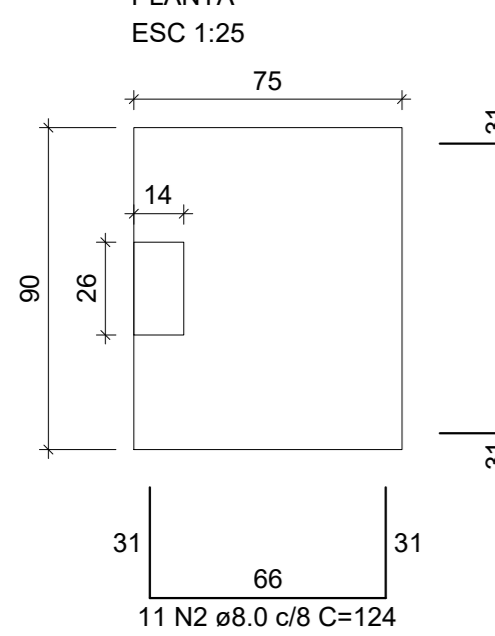

Table titled 'RELAÇÃO DO AÇO' showing steel reinforcement specifications: AÇO, N, DIAM (mm), QUANT, C UNIT (cm), C TOTAL (cm).

Table titled 'RESUMO DO AÇO' showing steel reinforcement summary: AÇO, DIAM (mm), C TOTAL (m), PESO + 10% (kg).

Volume de concreto (C-30) = 15.26 m³. Área de forma = 99.95 m².

S2=S3=S4=S5=S6=S7=S8=S9=S10=S11=S12=S13=S14=S16=S17=S18=S19=S20=S21=S22=S23=S24=S25=S26=S27=S29=S30=S31=S32=S33=S34=S35=S36=S37=S38=S39=S40=S41=S42=S43

P10=P11

P2=P3=P4=P5=P6=P7=P8=P9=P12=P13=P14=P16=P17=P18=P19=P20=P21=P22=P23=P24=P25=P26=P36=P39=P42

P27

P29=P30=P31=P33=P34

P32

P35=P38=P41

P37=P40=P43

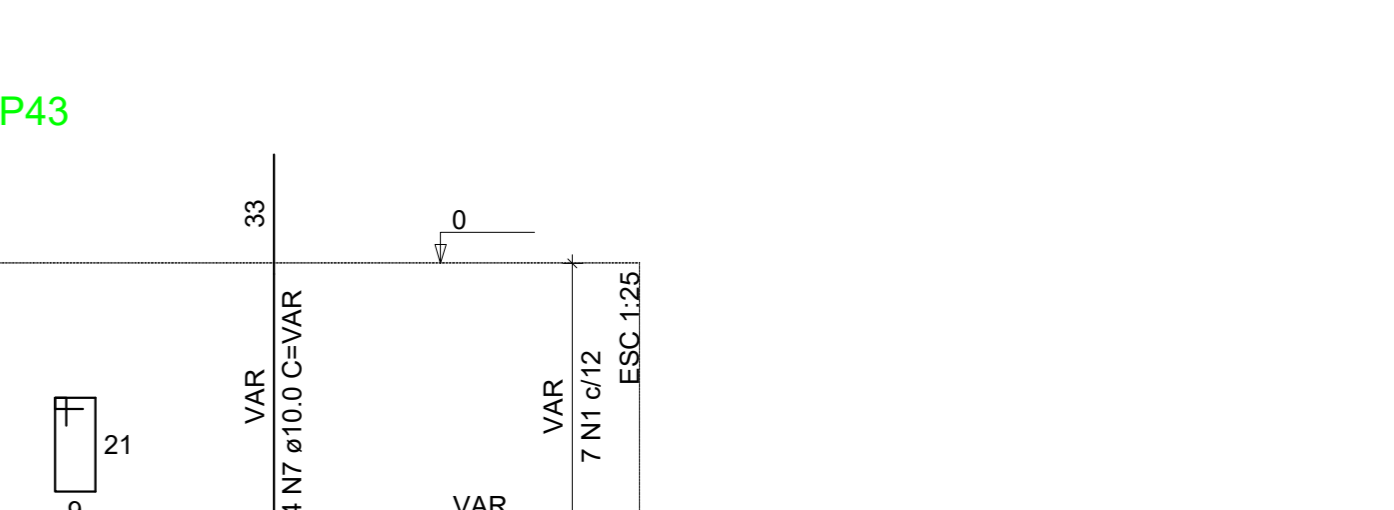
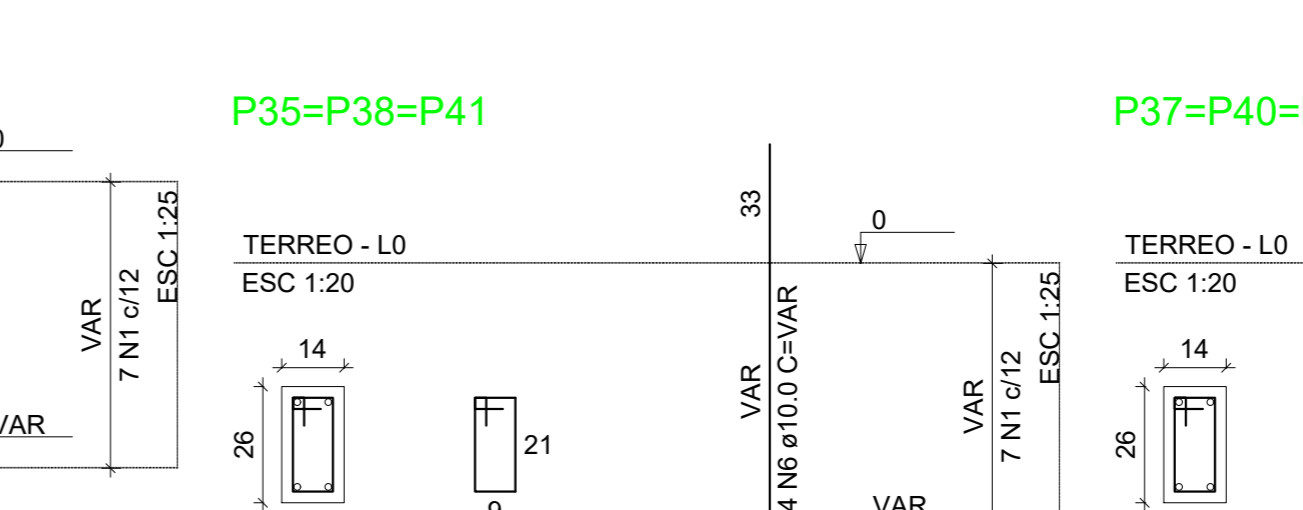
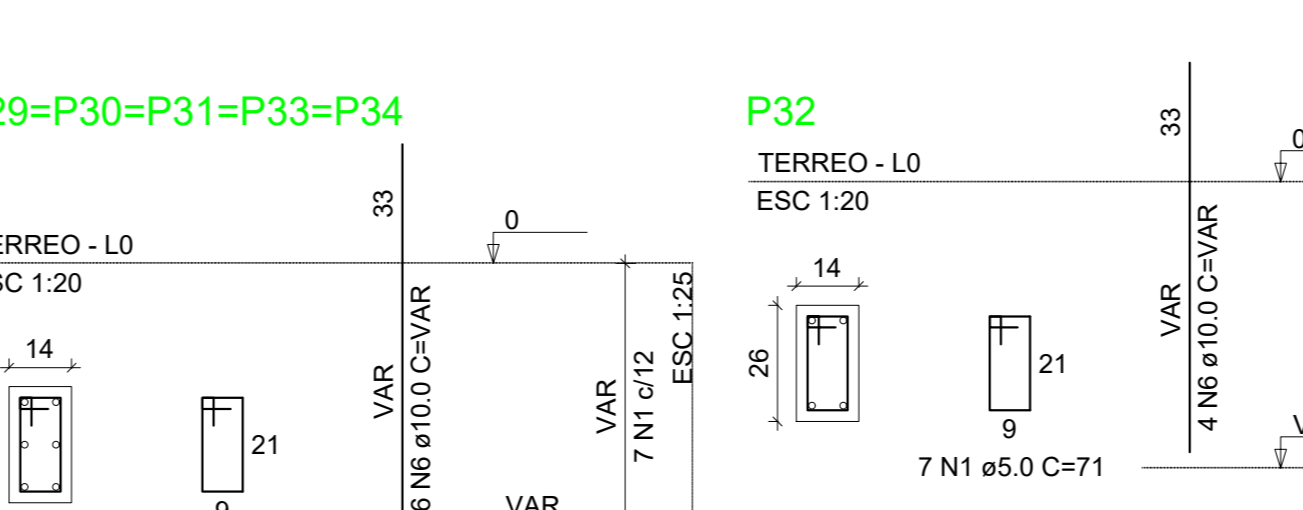
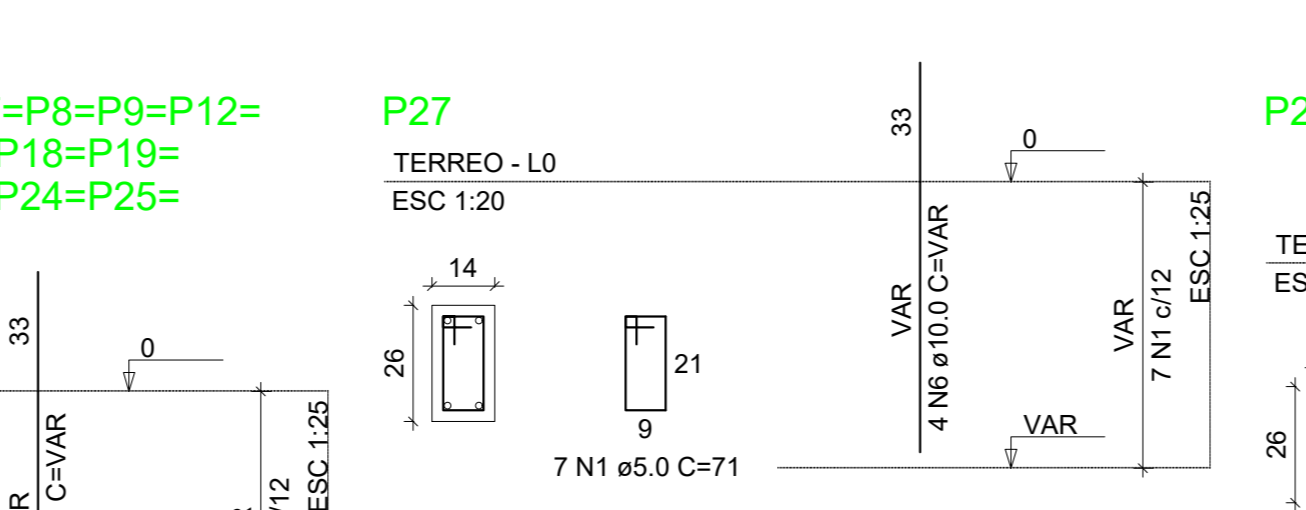
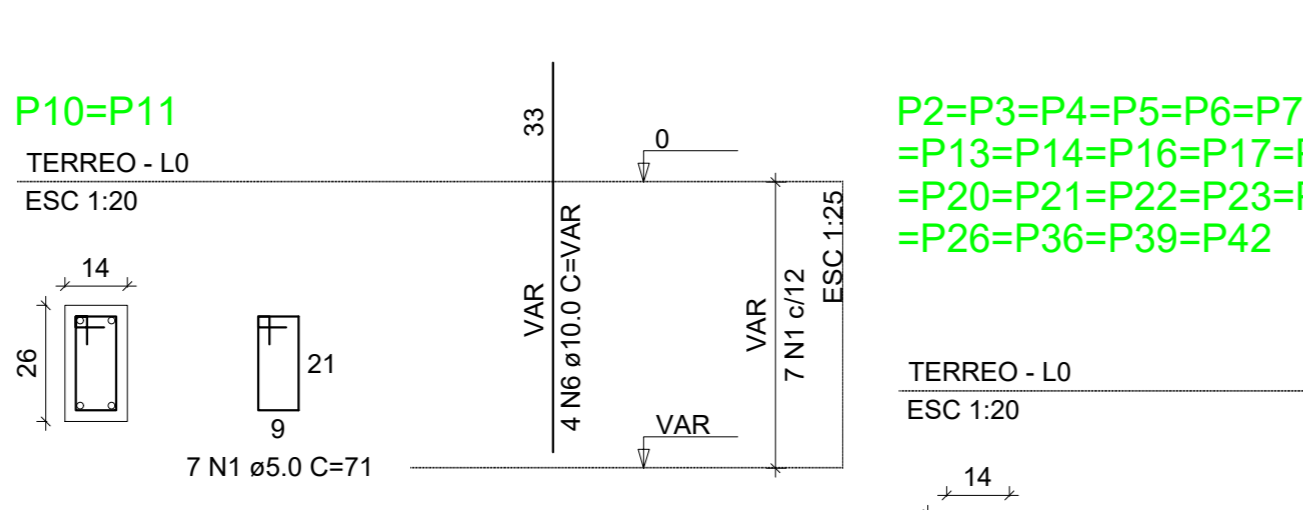
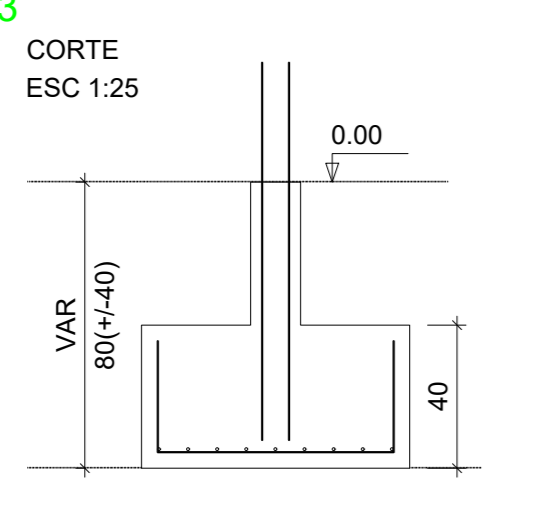
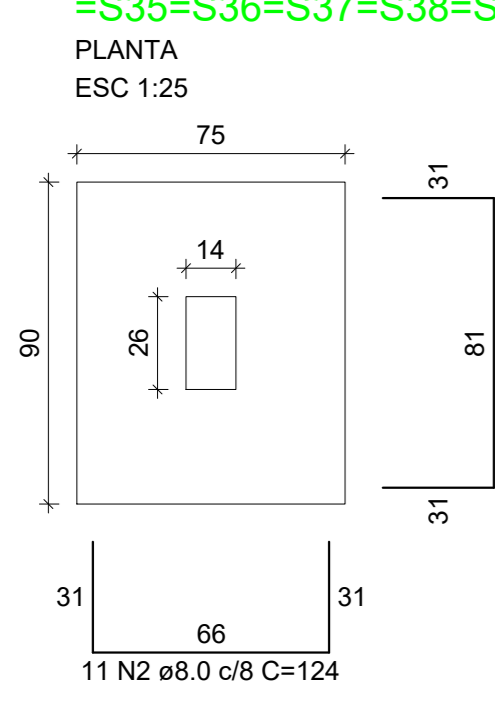

DADOS AUTOMÁTICOS REVISADOS - COMPARE ARTIGO 18 DO CÓDIGO PENAL, LEI 989 - DO CÓDIGO CIVIL E REVISÃO CONTRA 2017